

Architectural Surfaces, Inc.

123 Columbia Court North • Suite 201 • Chaska, MN 55318
952-448-5300 • Fax: 952-448-2613 • Toll Free: 1-800-448-3134

**OLD WORLD
COFFERED™**

OLD WORLD™ / NEW WORLD™ CEILING – SPECIFICATIONS

ARCHITECTURAL SURFACES, INC. 952-448-3134

Section 13070 Special Wood Coffered Ceiling System

Part 1: General

1.1 Scope:

- A)** The work in this section shall be subject to the requirements of the General Conditions.
- B)** Work Included: Furnish all labor, materials, equipment and services required in conjunction with the installation of the wood coffered ceiling system specified herein and identified on the drawings and schedules including:
 - 1) Concealed grid suspension system.
 - 2) Wood coffered ceiling system
 - 3) All factory applied and/or field installed accessories, wood moldings, or trim relating to the ceiling system.
 - 4) Integrated air diffusion (optional).
 - 5) Factory prefinishing (optional).
- C)** Related work specified elsewhere:
 - 1) Painting or finishing (optional).
 - 2) Acoustical work.
 - 3) Mechanical connections to integrated air components (optional).
 - 4) Balancing of air distribution system (optional).
 - 5) Millwork.

1.2 Quality Assurance:

- A)** Manufacturer: The manufacturer shall have a minimum of three years experience in laminating veneers, fabrics, high pressure laminates or metals to fire retardant substrates and shall have completed at least five projects of the scope and quality required by this project.
 - 1) The manufacturer shall have tested the lamination bond of the veneers or other facings to the substrate without showing signs of delamination, cracking or bubbling.
 - 2) Submit a list of representative installations completed during the last two years, listing the owner and approximate dollar value.

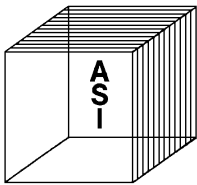

Architectural Surfaces, Inc.

123 Columbia Court North • Suite 201 • Chaska, MN 55318
952-448-5300 • Fax: 952-448-2613 • Toll Free: 1-800-448-3134

OLD WORLD COFFERED™

1.2 Quality Assurance:

- B)** Contract Execution: The bidding subcontractors shall be approved by the manufacturer's local distributor/representative of the specified materials and shall be thoroughly experienced in this type of work.

1.2 Submittals:

- A)** Contract Execution: The work of this section shall not be contracted for until all submissions required below have been completed and approved.
- A)** Test Data: Submit tests establishing compliance with all performance characteristics of the specification.
- C)** Shop Drawings: Submit shop drawings in detail of all work in scale to indicate size, location and attachment methods required for the installation of the required work.
- D)** Samples: Submit samples or portions of full size units showing jointing where such exists and methods of internal fastening as well as all other detailing required.

1.4 Warranty:

- A)** Submit at the time of submission of shop drawings, the manufacturer's warranty that the materials furnished hereunder will be free of manufacturing defects for a period of one (1) year. The manufacturer's warranty may be conditioned with a statement that damage resulting from wet job conditions, faulty construction, plumbing or ventilating systems is not covered by the warranty. The manufacturer's warranty is limited to replacement of defective material only, rather than installation of the same. Faulty installation shall be corrected by the installing contractor. The warranty required herein is the sole remedy against the manufacturer and there are no other implied warranties. In any event, the manufacturer shall not be liable for incidentals or consequential damages.

1.5 Substitute Products:

- A)** Proposal shall be based only on the specified product.
- B)** Alternative proposals for substitute products will not be accepted unless approved in writing via addenda.
- C)** Request for approval to submit an alternate proposal must be made a minimum of twenty-one (21) calendar days prior to bid date. Request must include test data, samples and product certification per paragraph 1.3 Submittals. If approval is granted an addenda will be issued, so stating a minimum of seven (7) calendar days prior to bid date.

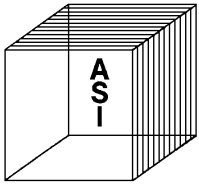

Architectural Surfaces, Inc.

123 Columbia Court North • Suite 201 • Chaska, MN 55318
952-448-5300 • Fax: 952-448-2613 • Toll Free: 1-800-448-3134

**OLD WORLD
COFFERED™**

Part 2: Products

2.1 Concealed Suspension System:

- A) Materials: The grid suspension system shall be as manufactured by Chicago Metallic Corporation, Armstrong or approved equal and shall have a 15/16" face width.
- B) All main runners and cross runners shall conform to the heavy duty classification of ASTM C635.
- C) Main runners shall be installed 48" o.c. and be directly suspended by not less than 12 ga galvanized steel wire wrapped tightly at least three full turns. Suspension wires shall be straight and vertically installed not more than 48" o.c.
- D) Main runners shall be interconnected by cross tees to form a _____ x _____ module.
- E) Wall channel moldings shall be standard cold rolled electrogalvanized steel with a 15/16" flange extending from the wall line.

2.2 Wood Coffered Ceiling System and Moldings:

- A) Materials: The lay in ceiling panels shall be faced with (flat cut, rift cut, quarter cut) (species of wood veneer) (brushed, mirrored or satin .025" thick metals in a brass, cooper, or natural finish, ASI style no. _____) (fabric, vinyl, luminous panel, or custom facing) style no. _____ as manufactured by _____. Panels shall be _____ x _____ in size and shall have a Class 1 (A), 0-25 flame spread rating.
- B) Panel Construction: The wall panel core shall be a minimum of 1/2" thick and shall be of (solid) (acoustical) material. (Solid panels shall be backed with a compatible material, resulting in a three ply construction to prevent excessive warping.) (Acoustical panel core shall provide a sound absorption coefficient of _____ NRC.) The panel core shall have a Class 1 (A), 0-25 flame spread rating.
- C) Solid Wood Moldings: the solid wood grid cover moldings shall be of _____ species and shall be (3/4" thick x 2" wide) (special size of _____" thick x _____" wide). The solid wood moldings shall be precisely coped and routed to fit over the grid suspension system and held in place with special concealed mechanical fastening clips.
- D) (Optional) Panel Trim Moldings: The wall panels shall have a decorative interior trim molding applied to panel in a pattern as shown on the drawings. Trim moldings are to match the other solid wood moldings as selected.
- E) (Optional) Panel Deep Coffe Moldings: Special solid wood moldings shall be used to form a trunkated coffer system _____" deep. Special moldings are to match the other solid wood moldings in species and finish.

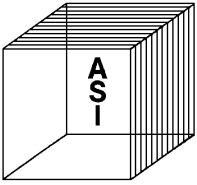

Architectural Surfaces, Inc.

123 Columbia Court North • Suite 201 • Chaska, MN 55318
952-448-5300 • Fax: 952-448-2613 • Toll Free: 1-800-448-3134

OLD WORLD COFFERED™

2.2 Wood Coffered Ceiling System and Moldings – Continued:

- F)** (Optional) Prefinished Panels and Moldings: Veneered panels or solid wood moldings shall be custom stained with no. _____ as manufactured by _____.
Surface finish shall be a (satin) (semi) gloss. (Number of coats and application to comply with A.W.I. Finish System No. _____). Finish to be reviewed and accepted by the Architect/Designer prior to its application to the wood.
- G)** Manufacture and Design: The wall panel system shall be (New World) – (Old World) as manufactured by Architectural Surfaces, Inc., (952) 448-5300 and distributed locally by _____.

Part 3: Execution

3.1 Job Conditions:

Upon receiving and prior to the installation of the interior finish materials, the installing contractor shall completely read all of the manufacturer's instructions for storage, job conditions and installation recommendations, and see that they are strictly complied with. Work shall not begin until the space is fully enclosed and glazed. All wet work is to be completed and dried out to the satisfaction of the architect. Temperature shall be a least 65 degrees Fahrenheit during the installation and thereafter. The installation contractor shall be responsible for the examination of all the conditions and recommendations as set forth and shall not proceed until satisfactory conditions have been met.

3.2 Installation:

Installation shall be in strict accordance with the manufacturer's recommendations, project specifications and the contract drawings. Installation shall be performed by trained crews under the direction of a trained foreman. Finished appearance in all cases shall be in exact conformance with the contract documents.

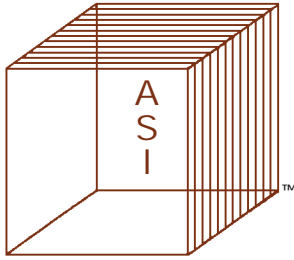

Architectural Surfaces, Inc.

DISTINCTIVE WOOD & SPECIALTY ACOUSTICAL CEILING & WALL SYSTEMS

123 Columbia Court North • Suite 201 • Chaska, MN 55318
952-448-5300 • Fax: 952-448-2613 • Toll Free: 1-800-710-8791
e-mail: info@architecturalsurfaces.net
Visit Our Web Site at www.architecturalsurfaces.net

CEILINGS YOU CAN LOOK UP TO!



Willamette Industries, Inc.

Duraflake Particleboard Plant

2550 Old Salem Road NE
P.O. Box 428
Albany, Oregon 97321
(541) 928-3341
FAX: (541) 928-4116

Dear Steve Anderson
Architectural Surfaces Inc
June 15, 2000
123 Columbia Court North, #201
Chaska, MN 55318

June 15, 2000

Dear Steve Anderson,

Thank you for your inquiry regarding Willamette Industries Duraflake FR and MR, our specialty particleboard products.

Duraflake FR is a Class A fire-rated wood corestock. The product has proven its excellent performance in the architectural woodwork industry for over 20 years. Duraflake FR is a particleboard substrate that is exceedingly well-suited for lamination with high-pressure decorative laminate and wood veneers. In addition, many other overlays have been applied to Duraflake FR, including, but not limited to: low pressure laminates, metal, glass, fabric, paper, vinyl, foils, and stone. The fire-retardant chemicals are an integral part of the particleboard construction and offer greater versatility than coated or pressure-treated products. The product can be sawed, bull-nosed, drilled, routed, shaped or precision machined without affecting the fire rating.

Furthermore, model codes allow that if a finish applied to the substrate is less than 1/28" (0.036"), the firerating of the substrate is unaffected and the entire construction carries the fire rating of the substrate.

Duraflake MR is a moisture resistant particleboard substrate that can be used in areas of high humidity or intermittent contact with water. Duraflake MR's many practical applications include institutional case goods, store and display fixture applications, storm door cores, mezzanine decking and many other situations where exposure to moisture is encountered.

Please review the enclosed materials describing Duraflake FR and MR. If you would like samples, or we can assist you with your specifications, please contact me.

Sincerely,

Geoff Gross
Sales Representative
Duraflake Division

Enclosures

Member: Composite Panel Association, PB-MDF Institute
Associate Member: Architectural Woodwork Institute; Kitchen Cabinet Manufacturers Association;
National Association of Store Fixture Manufacturers

HIGHEST QUALITY, GENUINE WOOD AND VENEER, SOUND CONTROL, DECORATIVE CEILING & WALL SYSTEMS, EASILY INSTALLED TO STANDARD T-BAR GRID ALLOWING CONCEALED SUSPENSION AND COMPLETE PLENUM ACCESS. OPTIONS INCLUDE LINEAR, CUBE, GRILLE, COFFER, CURVED, PERFORATED OR CUSTOM IN ANY WOOD SPECIES. ALL SYSTEMS AVAILABLE FACTORY FINISHED WITH CLASS A FIRE RETARDANT PAINT, CLEAR VARNISH OR STAIN. OTHER SOUNDPROOFING, SOUND ABSORBING AND NOISE CONTROL ACCESSORIES AVAILABLE FOR CEILINGS, WALLS AND FLOORS.

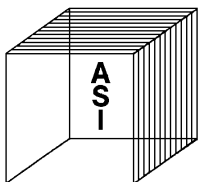

Architectural Surfaces, Inc.

123 Columbia Court North • Suite 201 • Chaska, MN 55318
952-448-5300 • Fax: 952-448-2613 • Toll Free: 1 -800-448-3134

OLD WORLD COFFERED™

OLD WORLD™ / NEW WORLD™

INSTALLATION RECOMMENDATIONS & INSTRUCTIONS

CAUTION: Do Not Install Until Instructions Have Been Read Completely.

WARNING:

All solid wood products are cellular and are subject to expansion, contraction, or warping. Under normal construction conditions, wood can expand or contract up to 1/8th of an inch per foot. Any wood veneered product is subject to blistering and/or crazing if exposed to excessive moisture, extremely dry conditions or sunlight. Panels **should not** be subject to high or low humidity, storage, should preferably be between 40 and 50 percent relative humidity. Storage, even for a short period of time, in areas where the humidity is over 60 or under 30 percent could cause permanent damage to the panels. (See Job Conditions). The manufacturer assumes no liability for expansion, contraction, or warping, blistering, crazing or delamination to panels that may have been exposed to extreme conditions. For the best installation results these instruction must be followed exactly.

RECEIVING:

Check cartons for any obvious shipping damage to the panels or moldings; if you feel there is concealed damage, open cartons and inspect. Have driver sign for any damaged panels and the consignee shall file a freight claim with the carrier at once. **The manufacturer assumes no responsibility for filing freight claims or for shortages.**

Make sure that all of the material ordered for the job has been received and is the proper style or styles and in the proper quantities.

If any panel appears to have manufacturing defects, do not install. The manufacturer's only obligation is replacing materials proven to be defective and that are returned for credit, within the terms and conditions of the sale. Notify the manufacturer or distributor/representative at once.

STORAGE:

Panels and moldings shall be stored in a flat horizontal position on wood blocking not more 12" o.c. Protect all panel faces from exposure to moisture or to light with dark colored polyethylene or similar material. Do not store panels or moldings in damp areas or in freshly plastered buildings. Terrazzo grinding must be completed and cement cured. Storage space must be dry and well ventilated.

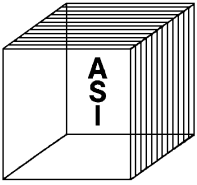

Architectural Surfaces, Inc.

123 Columbia Court North • Suite 201 • Chaska, MN 55318
952-448-5300 • Fax: 952-448-2613 • Toll Free: 1-800-448-3134

**OLD WORLD
COFFERED™**

JOB CONDITIONS:

Louvers shall be installed in areas where the same humidity and temperature conditions exist as will be in the final occupancy of the space. Do not install any panels in areas that are not fully enclosed or are exposed to dampness or moisture. **If panels are to be stored for more than one week, they should be totally sealed, front, back and all edges, to protect against the effects of moisture.**

Seventy-two hours prior to installation open all cartons or crates and lay panels in a flat horizontal position. Place lath spacers 12 inches on center below and between each row of panels to allow air to circulate around them. The panels must adjust to the temperature and humidity of the space they are to be installed to alleviate excessive expansion or contraction.

JOB FINISHING:

Solid wood moldings and veneered panels are pre-sanded; subsequent grain raise handling or tool marks must be removed before final finishing. Sand exposed surface lightly with No. 400 sandpaper. Never use steel wool on bare wood. **Apply sanding sealer to face, back, and all edges** to balance the panel. Apply one or two coats of varnish or lacquer to the exposed surfaces. Sand lightly between first and second coat. Be sure the finish doesn't violate local fire codes.

OILS, STAINS AND FILLERS:

Do not use water-based stains, combination stain-sealers are not recommended. Do not use penetrating oil stains, linseed oil or wax finishes.

Danish or Swedish (quick drying) type oils are satisfactory. Apply moderately with a cloth; do not saturate the wood, wipe dry quickly with a clean dry cloth.

MINERAL STREAKING OR BLUE STAIN IN OAK:

Occasionally this may occur in oak panels by natural tannic acid in the wood. This does not show up in the manufacturing process, only after the veneer has come in contact with moisture. Should this occur, the stains can be removed, contact the varnish manufacturer for recommendations.

CEILING SUSPENSION SYSTEM:

Box type edge moldings are recommended. Main tees and cross tees shall conform to heavy duty classification ASTM C635. Install main tees 4' o.c. with #12 pre-straightened galvanized steel wire not more than 4' o.c. wrapped tightly at least three full turns. Cross tees shall be installed to form a 2' x 2' or 2' x 4' module as required. (If grid system is an existing 2' x 2' module, use a variable

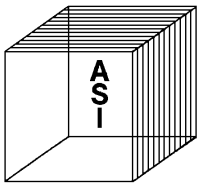

Architectural Surfaces, Inc.

123 Columbia Court North • Suite 201 • Chaska, MN 55318
952-448-5300 • Fax: 952-448-2613 • Toll Free: 1-800-448-3134

**OLD WORLD
COFFERED™**

CEILING SUSPENSION SYSTEM – CONTINUED:

placement cross tees to form a 2' module.) Install extra hanger wires at lights or as required to support the wood panel system check with the grid system manufacturer for proper o.c. hanger spacings if in doubt.

GENERAL INSTALLATION SEQUENCES:

Wood naturally varies in color and grain characteristics. It is recommended that panels or moldings be presorted before installation to assure a uniform appearance.

NEW WORLD/OLD WORLD CEILING SYSTEM:

1. install clips to grid, 2' o.c. max. Slide long tongue over tee flange and push up with thumb on one corner of short flange on the other side.
2. Install part no. 8 – 2' o.c. stager joints as required. Cut ends flush with walls. At all walls, molding pieces are to be ripped down to widths as required, see note below.

Important Note:

Ripped down moldings must leave 22" edge to edge or 22-3/4" end of cope to end of cope for cross members (part 1) to fit.

3. Install field cross moldings (part no.1).
4. Rip down edge cross moldings (part no. 1), (see note above).
5. Cut holes and or fit border panels as required. With odd shaped panels, apply interior trim moldings after panels are fit.
6. Install panels.

NEW WORLD/OLD WORLD WALL SYSTEM: (For 1/2" thick panel system)

1. Install wood fillers into 3" black molding clips.
2. Slide clips into aluminum channels, 2' o.c. max., and 3" from each end.
3. At center line of wall install 3/8" thick x 1-3/16" wide plywood furring strips and vertical aluminum clip retainer channel (must be plumb).
4. Center and level cross aluminum channels and furring strips (per drawing) each side of vertical. (At this point make sure the wood moldings fit and the coped ends will close up tight).
5. Install vertical or cross channels and furring strips progressively, using 22 13/16" cross channels as spacing guides, Check periodically for gain or loss with Old World wood molding parts.

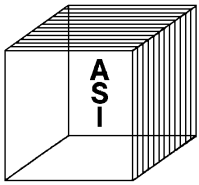

Architectural Surfaces, Inc.

123 Columbia Court North • Suite 201 • Chaska, MN 55318
952-448-5300 • Fax: 952-448-2613 • Toll Free: 1-800-448-3134

**OLD WORLD
COFFERED™**

OLD WORLD CEILING WALL – CONTINUED:

Important Note:

All aluminum clip retainer channels must be installed level and plumb with intersections square in order for wood moldings to fit properly. Aluminum clip retainers and furring strips can be installed with contact adhesive and/or screws. The combination thickness of the furring strip and clip retainer must be a total of 11/16" to engage the clip properly.

6. Install wall panels with contact adhesive.
7. Install long vertical or horizontal wood moldings. Use clips at butt joints.
8. Install short moldings. (Some pieces may require job coping on one end, use standard 3/8" router bit).
9. Cut down wood edge trim moldings to width required and install.
10. Install base and trim as required.

NOTICE:

The above recommended installation instructions are reliable for most installations, but are not meant to imply any warranty or guarantee for which Architectural Surfaces, Inc. assumes responsibility. The installer must undertake testing and verification as to specific applications to determine suitability for them prior to installation.

The manufacturer's only obligation is to replace any material proven to be defective, rather than the installation or removal of the same, for a period of one year from the date of shipment. Faulty installation shall be corrected by the installing contractor. Beyond the purchase price of the materials supplied, the manufacturer assumes no liability for damages of any kind and the user accepts the product "as is" without warranties expressed or implied. The suitability of the product for an intended use shall be solely up to the user.

©ARCHITECTURAL SURFACES, INC.

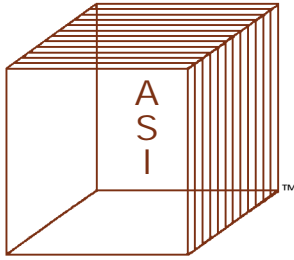

Architectural Surfaces, Inc.

DISTINCTIVE WOOD & SPECIALTY ACOUSTICAL CEILING & WALL SYSTEMS

123 Columbia Court North • Suite 201 • Chaska, MN 55318
 952-448-5300 • Fax: 952-448-2613 • Toll Free: 1-800-710-8791
 e-mail: info@architecturalsurfaces.net
 Visit Our Web Site at www.architecturalsurfaces.net

CEILING YOU CAN LOOK UP TO!

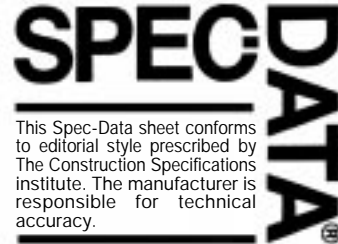

This Spec-Data sheet conforms to editorial style prescribed by The Construction Specifications Institute. The manufacturer is responsible for technical accuracy.

1. PRODUCT NAME

Fire-Rated Particleboard
 Duraflake FR

2. MANUFACTURER

Willamette Industries, Inc.
 Duraflake Divisions
 Building Materials Group
 PO Box 428
 Albany, OR 97321
 Phone: (541) 928-3341
 FAX: (541) 928-4116

3. PRODUCT DESCRIPTION

Basic Use: Duraflake FR is a Class 1 rated fire retardant particle board, suitable for a variety of industrial and commercial building applications where stringent building codes, public safety requirements or reduced insurance rates are a factor. It is used as a substrate for wood veneers, high and low pressure laminates and vinyls in wall systems, as well as furniture and fixtures. It can be drilled, routed, bullnosed, beveled and precision-machined without affecting the flame spread rating.

Limitations: Duraflake FR should be specified for interior use only.

Composition and Materials: Duraflake FR is made from Western soft wood particles and highly effective fire retardant chemicals bonded with special formulas of resins and waxes.

Grade: Industrial Grade

Sizes: Standard-4' x 6', 4' x 8', 4' x 10', 4' x 12', 5' x 8'. Other sizes available upon request from distributor.

Finishes: From outside sources, Duraflake FR is available laminated with wood veneer and low pressure laminates. Please call **Architectural Surfaces Inc.** at **1-800-710-8792** for availability or quote on laminated panels.

Note: Some laminates applied to Duraflake FR may change the flamespread rating of the composite panel. Applicable Standards: ASTM E84 tunnel test. Material and Equipment Acceptance Division, New York City. ASTM C 236, Guarded Hot Box test. UL 723 Test for Surface Burning Characteristics of Building Materials.

Chemical Properties: Available upon request.

5. INSTALLATION

Preparatory Work: Duraflake FR is a wood based panel and is considered an interior product. It must never be stored or used outside. Store flat under constant relative humidity and temperature conditions. Allow to stabilize prior to use.

Physical Properties of Duraflake FR:

	Duraflake FR* 3/8"-3/4"	Duraflake FR 13/16"-1-1/4"
Density (lbs./cu ft.)	45.0	44.0
Modulus of Rapture	1600 psi	1300 psi
Modulus of Elasticity	300,000 psi	300,000 psi
Internal Bond	80 psi	60 psi
Elongation	0.40%	0.35%
Screw-holding		
Face	250	250
Edge	225	175

*Conforms to ANSI A208.1-1987, Grade 1-M-1

4. TECHNICAL DATA

Underwriters' Laboratories, Inc.:
Classified Wood Particleboard:
 Surface Burning characteristics, UL 723 (Based on 100 for untreated red oak).

Flame Spread	20
Smoke Developed	25

See UL Classified Building Materials Index. Listed under Wood Particleboard.

Thermal Conductivity (k) and thermal Resistance (1/k = R)*:

	3/8"	1/2"	3/4"	1"
k=	0.54	0.62	0.55	0.69
R=	1.85	1.61	1.82	1.45

*R and K values obtained using ASTM C 236 "Thermal conductance and transmittance of built-up wall sections by means of the 'Guarded Hot Box' in tests conducted by Northwest Testing Laboratories."

Ideally those conditions should be the same as those expected after the panel is installed. Laminates, if any, must be conditioned to the same state as Duraflake FR During installation, good practices standard to fine woodwork must be used. Please contact the Architectural Woodwork Institute (AMI) at (703) 222-1100 or Woodwork Institute of California (WIC) at (916) 233-9035 for specific standards. When used in wall systems, an integral vapor barrier must be part of the wall if the wall is exterior or the wall separates spaces conditioned unequally.

Methods: Duraflake FR can be laminated with both hot and cold press laminates. Balanced construction is advised. Most standard available woodworking

Continue on next page.

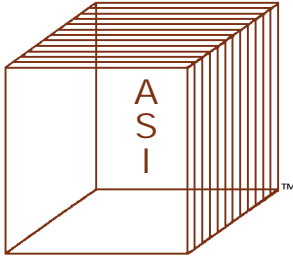

Architectural Surfaces, Inc.

DISTINCTIVE WOOD & SPECIALTY ACOUSTICAL CEILING & WALL SYSTEMS

123 Columbia Court North • Suite 201 • Chaska, MN 55318
952-448-5300 • Fax: 952-448-2613 • Toll Free: 1-800-710-8791

e-mail: info@architecturalsurfaces.net

Visit Our Web Site at www.architecturalsurfaces.net

CEILING YOU CAN LOOK UP TO!

glues have been successfully used in laminating. However, some adhesives have compatibility problems with the chemical system used to treat Duraflake FR. Any adhesive should be tested for compatibility before full scale gluing. Any questions about compatibility, spread rates, cure times and press temperature should be directed to the glue supplier or the manufacturer.

Hot Pressing: When hot pressing laminates on Duraflake FR, use the shortest cycle time allowable within the range specified by laminate and glue suppliers. Extended cycle times or high heat may induce blows. Due to the interaction of high heat and the chemical treatment, some low pressure paper laminates may exhibit visual changes in opacity. In hot pressing, care must be taken to cool the panels to 140°F before stacking to preclude heat degradation.

Cold Pressing: Urea, casein and epoxies have been used successfully

to bond laminates to Duraflake FR. Some contact cements and PVAs are incompatible. Their suitability should be cleared before using. With resorcinol glues, certain conditions are needed for best results due to the slightly acidic nature of the retardant chemicals, which tend to slow down cure rates.

Building Codes: BOCA, ICBO and SBCCI

Agency Approvals: City of New York MEA 177-78-M; State of California Fire Marshal 2660-831:1; City of Los Angeles PR 24811; City and County of San Francisco 258W34.1

6. AVAILABILITY AND COST

Availability: Duraflake FR is available from **Architectural Surfaces Inc. 1-800-710-8792.**

e-mail: info@architecturalsurfaces.net

Cost: Call **Architectural Surfaces Inc. 1-800-710-8792** for current costs.

7. WARRANTY

The Durafake Division of Willamette Industries, Inc. warrants Durafake FR to be free of manufacturing defect, both in material and workmanship. Durafake FR will perform in accordance with the specifications and applications listed when used according to directions herein. No other warranty or guarantee is made.

8. MAINTENANCE

None required for interior use when installed in conformance with manufacturer's instructions.

9. TECHNICAL SERVICES

For details concerning the technical aspects of Duraflake FR, call (541) 928-3341 or FAX (541) 928-4116.

10. FILING SYSTEMS

• CSI's SPECSEARCH™

• IHS' SPEC-DATA II

• Additional product information, full literature and technical assistance available upon request.

OLD WORLD™ DEEP COFFER CEILING SYSTEM

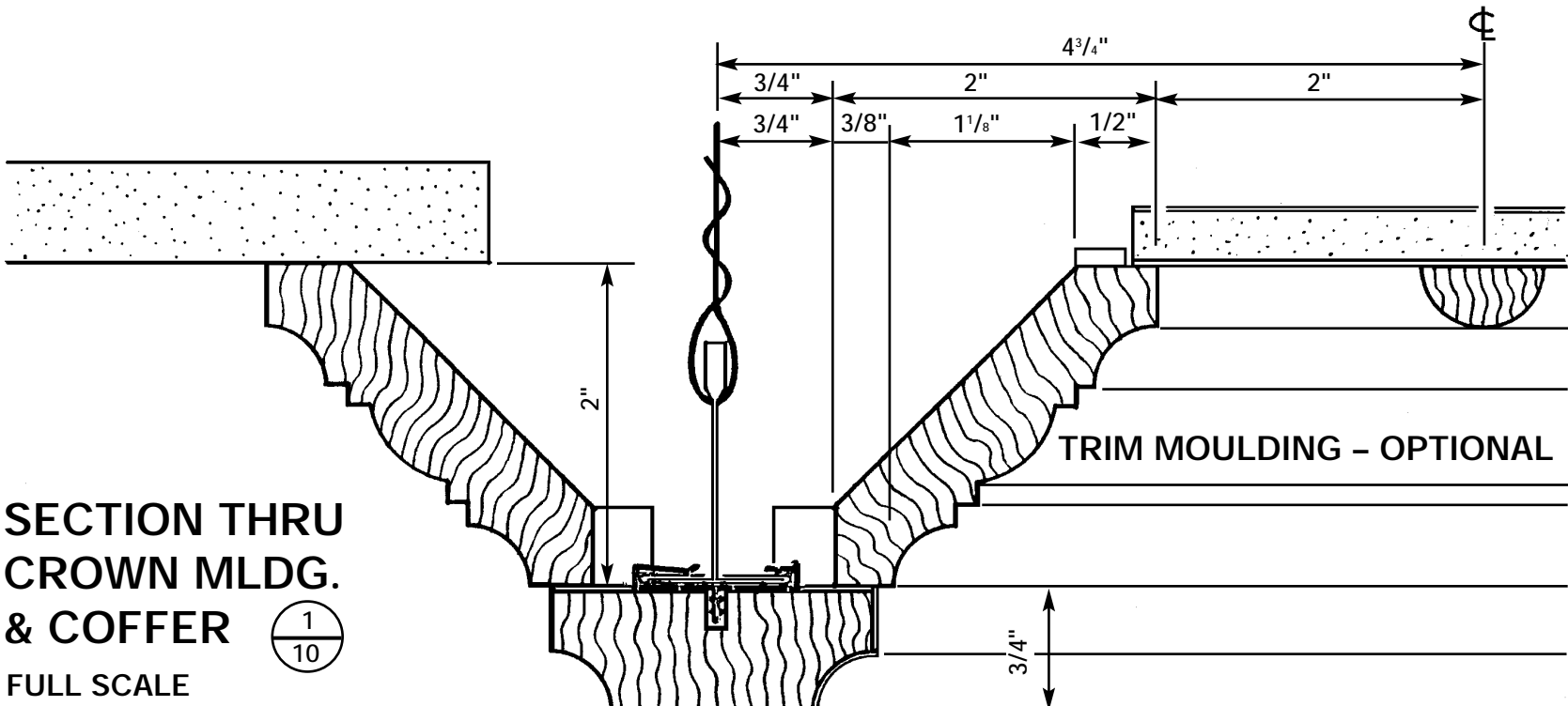

**SECTION THRU
CROWN MLDG.
& COFFER** 1
10
FULL SCALE



**ONE PIECE LAY-IN
COFFER DETAIL** 2
10
FULL SCALE

NOTE: See Other
Detail Sheets
for Typical Notes

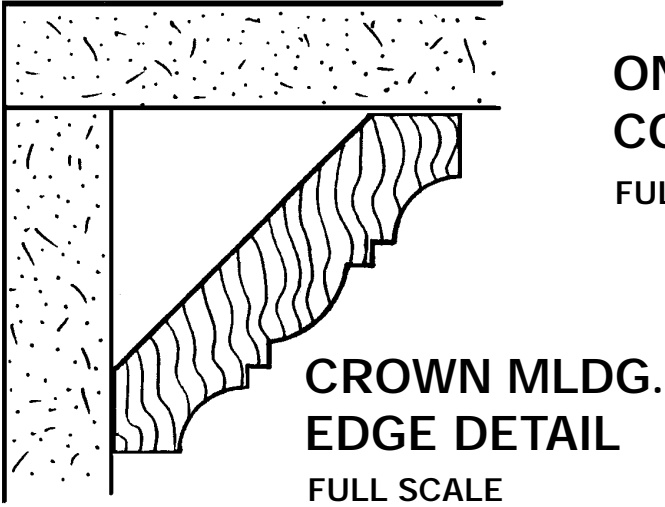

**CROWN MLDG.
EDGE DETAIL** 3
10
FULL SCALE

AVAILABLE IN MOST SPECIES OR CUSTOM SIZES
ON FACTORY APPROVAL

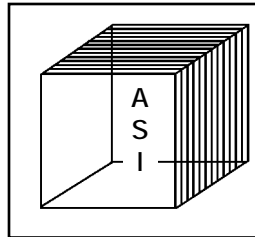

Architectural Surfaces Inc.
123 Columbia Court North
Chaska, MN 55318
PH# 952-448-5300
FAX# 952-448-2613

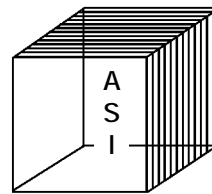
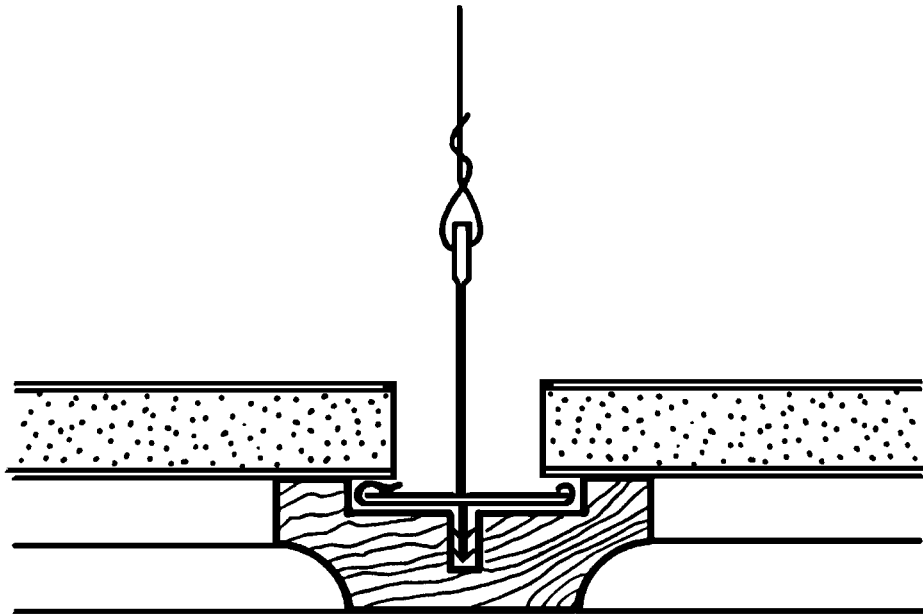

Architectural Surfaces Inc.
123 Columbia Court North
Suite 201
Chaska, MN 55318
PH# 952-448-5300
FAX# 952-448-2613

OLD WORLD™ CEILING DETAILS

Variable Placement Tee Snaps
Into Existing Grid System

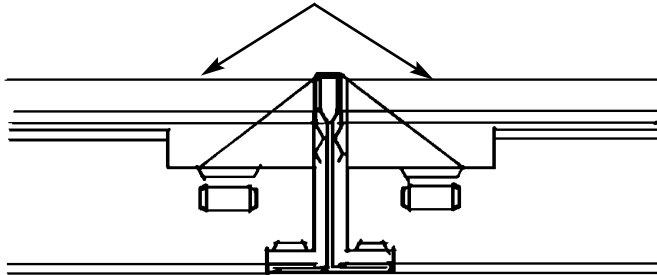

SECTION THRU VARIABLE PLACEMENT CROSS TEE

SCALE 3/4 FULL

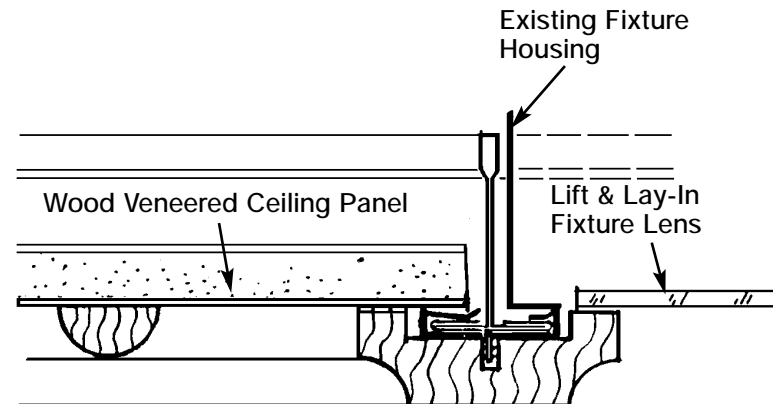

SECTION THRU RENOVATED FIXTURE & LENS

SCALE 3/4 FULL

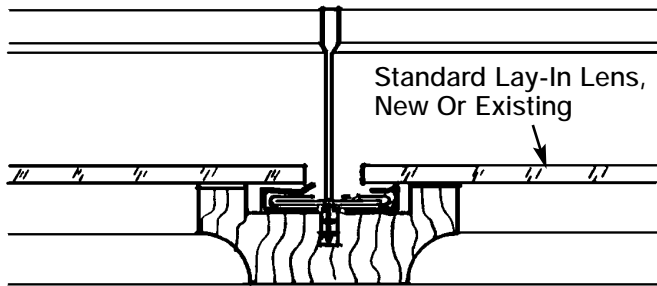

SECTION THRU LUMINOUS CEILING GRID SYSTEM

SCALE 3/4 FULL

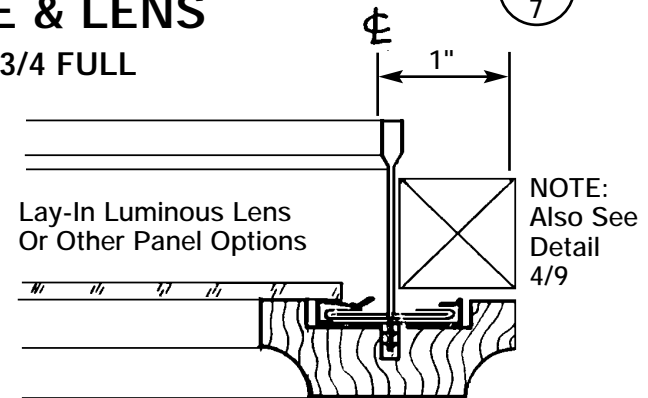

OPTIONAL WALL MLDG.



SCALE 3/4 FULL

AVAILABLE IN MOST SPECIES OR CUSTOM SIZES
ON FACTORY APPROVAL

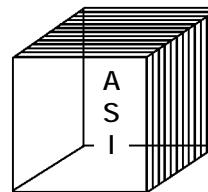

Architectural Surfaces Inc.
123 Columbia Court North
Suite 201
Chaska, MN 55318
PH# 952-448-5300
FAX# 952-448-2613

OLD WORLD™ CEILING DETAILS

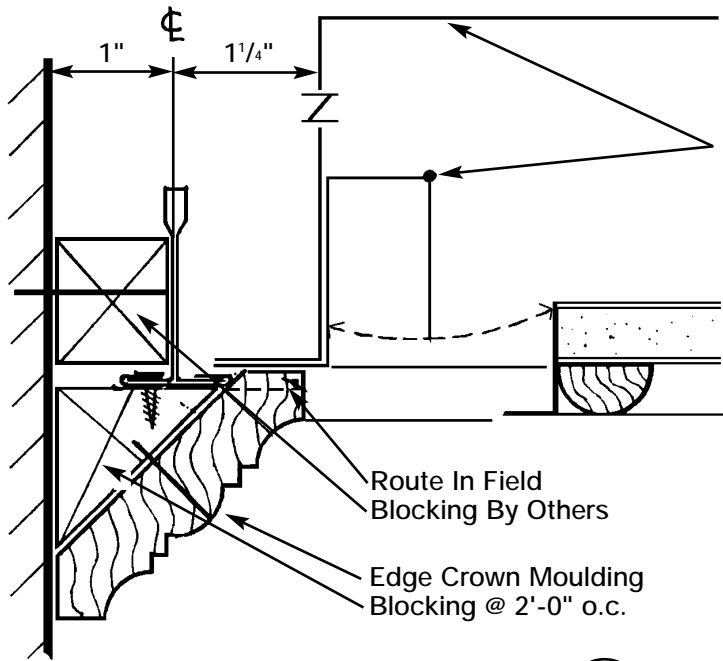

AIR RETURN • DETAIL (1/5) SCALE 3/4 FULL

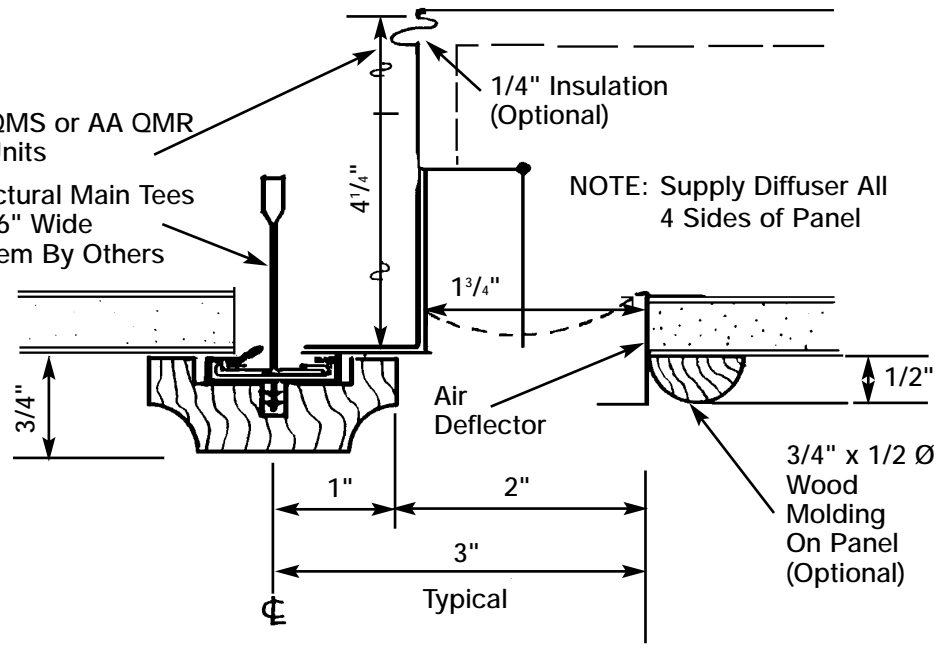

AIR SUPPLY DETAIL (3/5) SCALE 3/4 FULL

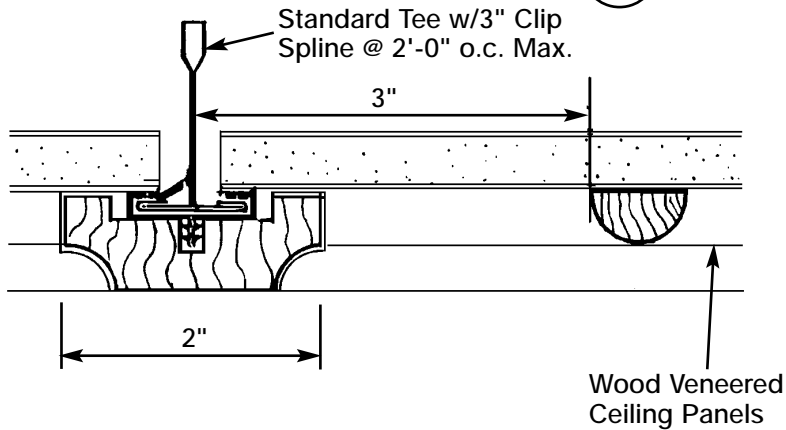

TYPICAL PANEL DETAIL (2/5) SCALE 3/4 FULL

*See Additional Notes On (1/5)

NOTE: All Notes & Dimensions Shown Are Typical For The "Old World System"

AVAILABLE IN MOST SPECIES OR CUSTOM SIZES ON FACTORY APPROVAL

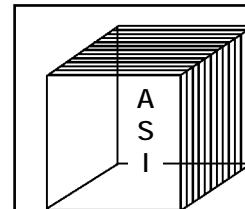

Architectural Surfaces Inc.
 123 Columbia Court North
 Suite 201
 Chaska, MN 55318
 PH# 952-448-5300
 FAX# 952-448-2613

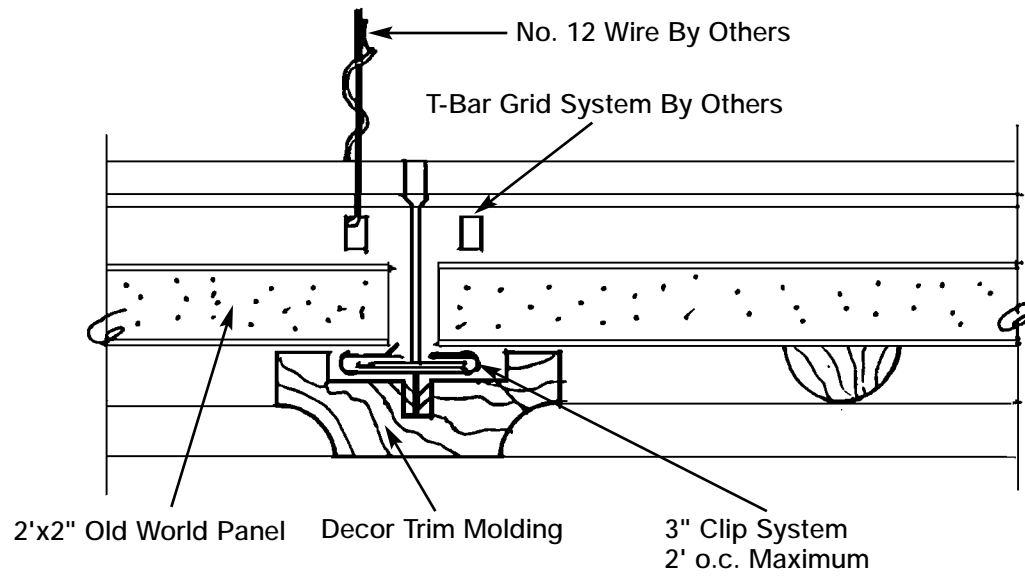

⊖ **DETAIL @ CROSS TEE SECTION** NO SCALE



Architectural Surfaces Inc.
123 Columbia Court North
Suite 201
Chaska, MN 55318
PH# 952-448-5300
FAX# 952-448-2613

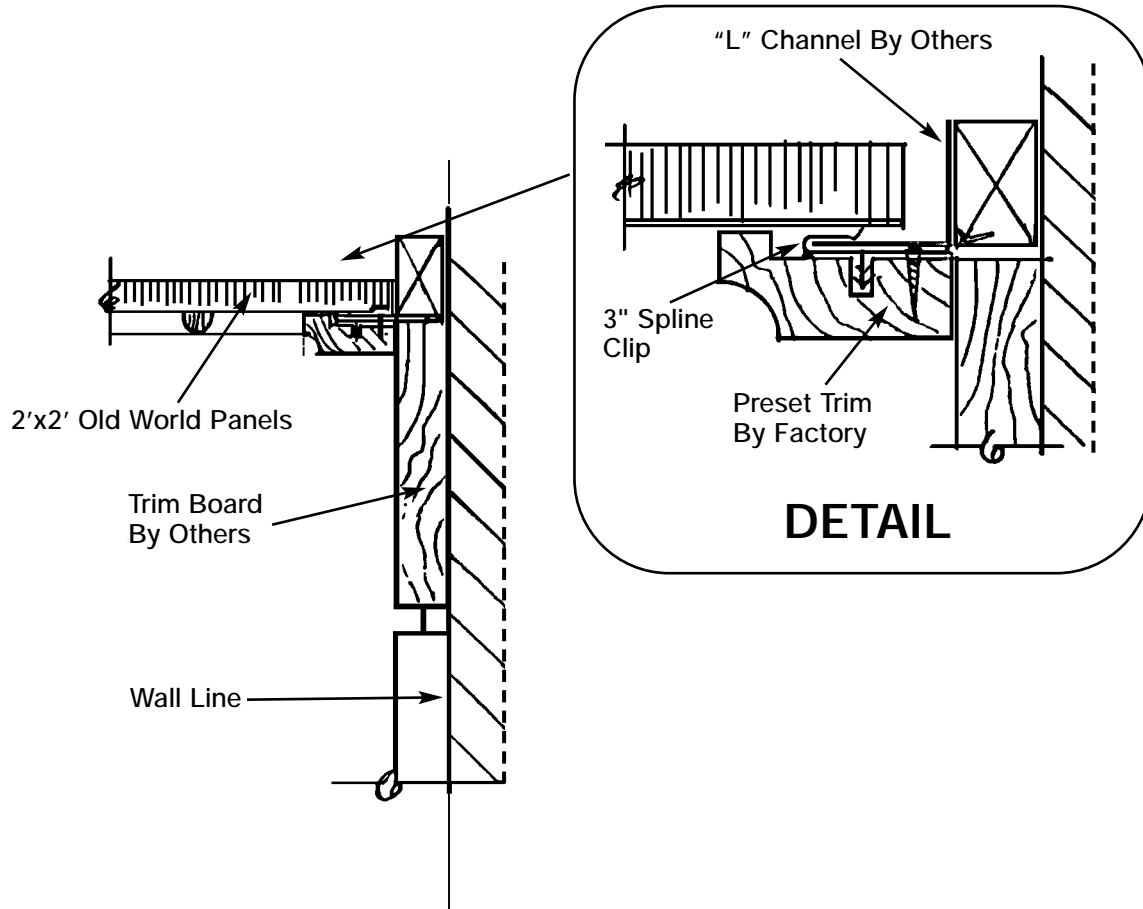

⊙ **DETAIL @ WALL**

3" = 1'-0"

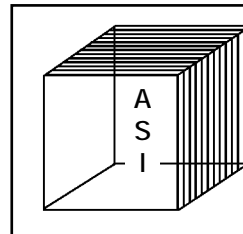

Architectural Surfaces Inc.
123 Columbia Court North
Suite 201
Chaska, MN 55318
PH# 952-448-5300
FAX# 952-448-2613

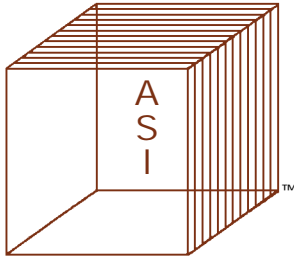

Architectural Surfaces, Inc.

DISTINCTIVE WOOD & SPECIALTY ACOUSTICAL CEILING & WALL SYSTEMS

123 Columbia Court North • Suite 201 • Chaska, MN 55318
952-448-5300 • Fax: 952-448-2613 • Toll Free: 1-800-710-8791
e-mail: info@architecturalsurfaces.net
Visit Our Web Site at www.architecturalsurfaces.net

CEILINGS YOU CAN LOOK UP TO!

BURN BARRIER™ 6 CLEAR WOOD SEALER FOR BURN BARRIER 166 CLASS "A" FIRE RETARDANT VARNISH SYSTEM.

Product Description:

BURN BARRIER™ 6 is a crystal clear, hardwood sealer developed primarily for use with Fire Retardants Inc. #166 Retardant Varnish. *NOTE: BURN BARRIER™ 166 is part of a fire retardant varnish system and is not a fire retardant when used alone.*

Surface Preparation:

Surfaces must be clean, dry and free from all loose or powdery materials, grease, wax or other foreign matter. All staining and filling must be done using nonbleeding type stains prior to the application of BURN BARRIER™ 6 Sealer.

Application:

(New Work) Previously uncoated surfaces:

Apply a full bodied coat by brush, at a coverage rate of 300 to 450 square feet gallon. Coverage rate depends upon the porosity of the wood. Highly porous woods may require a second coat of BURN BARRIER™ 6 Sealer.

(Old Work) Previously coated surfaces:

Previously varnished surfaces must be sanded to remove all gloss, loose or poorly bonded varnish. Test patch a small area to determine the compatibility of BURN BARRIER™ 6 Sealer with existing coating, to insure that no lifting or wrinkling occurs. If lifting or wrinkling develops, it is necessary to completely remove the old finish before proceeding.

Coverage

300 to 450 square feet per gallon, depending on porosity of the wood.

Thinners

For thinning and cleaning equipment, use only BURN BARRIER™ 6 Reducer.

Information provided herein is based on tests believed to be reliable. Inasmuch as Fire Retardants Inc. has no control over the use or application to which others may put this material, we make no guarantee or warranty. Our products are sold on the condition that each user of the material make their own evaluation to determine the material's suitability for their own particular use.

NOTE: All porous surfaces should be properly sealed before applying fire retardant paint or varnish.

CAUTION: It is recommended that a test application be completed prior to end use.

© Fire Retardants Inc. All Rights Reserved.

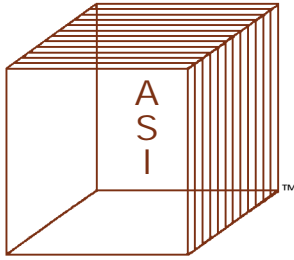

Architectural Surfaces, Inc.

DISTINCTIVE WOOD & SPECIALTY ACOUSTICAL CEILING & WALL SYSTEMS

123 Columbia Court North • Suite 201 • Chaska, MN 55318
952-448-5300 • Fax: 952-448-2613 • Toll Free: 1-800-710-8791
e-mail: info@architecturalsurfaces.net
Visit Our Web Site at www.architecturalsurfaces.net

CEILINGS YOU CAN LOOK UP TO!

BURN BARRIER™ 166 CLEAR CLASS "A" FIRE RETARDANT "INTUMESCENT" VARNISH

Product Description:

BURN BARRIER™ 166 is a clear satin finish fire retardant varnish having a Class "A" Underwriters' Laboratory flame spread rating. When exposed to flame or high heat, the coating puffs up to form a thick insulating cellular foam. This foam layer retards the penetration of heat, thereby reducing the flame spread (surface burning characteristics) and smoke development of combustible materials.

BURN BARRIER™ 166 is designed for use on interior wood surfaces where it is desirable to maintain the natural wood appearance, while obtaining a Class "A" flame spread rating. BURN BARRIER™ 166 is suitable for use on wall paneling, ceiling panels and other such surfaces. We do not recommend this product for use on floors, doors, shelving, or in areas where there will be exposure to excessive moisture or splashing of water, as the coating is somewhat softer than conventional varnishes. (On hard use surfaces we recommend BURN BARRIER™ 129 and BURN BARRIER™ 130 Class "B" Fire Retardant Varnish System.) BURN BARRIER™ 166 dries to a clear velvety satin finish. All surfaces that will be subjected to handling, washing or where a low, semi or hi-gloss finish is desired, should be overcoated with BURN BARRIER™ 167 UL rated Fire Retardant Varnish Overcoat. The use of BURN BARRIER™ 167 Overcoat greatly improved the moisture resistance, durability and cleansibility of BURN BARRIER™ 166.

Surface Preparation:

(New Work Previously uncoated surfaces All surfaces. must be dry, clean, free of all wax, grease, dirt, sanding dust, etc. If staining is desired, the use of nonbleeding type stains are recommended. All surfaces should be thoroughly sealed with BURN BARRIER™ 6 Clear Wood Sealer. Allow the surface to thoroughly dry before proceeding with the application of BURN BARRIER™ 166. It is recommended that a representative sample of the system be prepared prior to starting the project.

(Old Work Previously coated surfaces All surfaces. which have been previously coated with a conventional coating (this includes prefinished wood paneling), must be washed down with mineral spirits or other suitable solution, to remove all wax, grease, etc. Lightly sand or steel wool all glossy surfaces, test patch small areas, if old coating is not affected, proceed with the application of BURN BARRIER™ 166. If old coating is affected, it will be necessary to completely remove the coating before applying BURN BARRIER™ 166.

NOTE: On prefinished wood paneling, it may be necessary to seal the grooved areas, as most panel manufacturers only stain these areas and the grooves are highly porous.

© Fire Retardants Inc. All Rights Reserved.

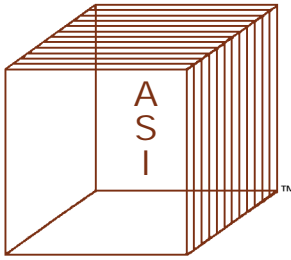

Architectural Surfaces, Inc.

DISTINCTIVE WOOD & SPECIALTY ACOUSTICAL CEILING & WALL SYSTEMS

123 Columbia Court North • Suite 201 • Chaska, MN 55318
 952-448-5300 • Fax: 952-448-2613 • Toll Free: 1-800-710-8791
 e-mail: info@architecturalsurfaces.net
 Visit Our Web Site at www.architecturalsurfaces.net

CEILING YOU CAN LOOK UP TO!

Application:

BURN BARRIER™ 166 can be applied by brush, conventional or airless spray. On wood paneling and other large surface areas, spray application is suggested as it will yield a more uniform finish. When spray applied the use of heavy duty spray equipment is recommended. Should thinning be required for spray application, use only BURN BARRIER™ 166 Reducer. After surface preparation has been carried out, apply a uniform coat of BURN BARRIER™ 166 without dilution, at a coverage rate of 300 sf/US gallon (7.4 m IL). Allow the surface to dry a minimum of 16 hours, or until hard. Then apply another coat as above. NOTE TWO COATS ARE REQUIRED. If the surface is to be over coated with BURN BARRIER™ 167 Overcoat, allow at least 48 hours drying time before applying BURN BARRIER™ 167.

Thinners:

For thinning and cleaning equipment, use only BURN BARRIER™ 166 Reducer.

CAUTION: The liquid coating contains volatile (combustible) solvents. Due care must be exercised during and after application until coating is dry.

Fire Tests:

Flame Spread Rating, Class "A". When tested in accordance with ASTM E84 (NFPA255) the coating obtained the following fire hazard classification. A complete report from the UNDERWRITERS' LABORATORIES is available upon request.

<u>Coating System Details</u>	<u>When Applied to Douglas Fir</u>			
	<u>*Flame FSC</u>	<u>Spread (GWL)</u>	<u>Smoke Developed</u>	<u>Fuel Contr.</u>
Type 6 (sealer) applied in one coat a 400 sf/US/gal. (9.8 m ² /L) Type 166 (base coat) applied in two coats at 300 sq/US gal. per coat (7.4m ² /L) (No topcoat)	25	(15)	50	15

Type 6 (sealer) applied in one coat a 400 sq/US gal. (9.8 m ² /L) Type 167 (top coat) applied in one coat at 1800 sq.US gal. (44.2 m ² /L)	25	(15)	30-50	10

*Flame Spread Ratings FSC = Canadian Rating
 (GWL) = U. S. Rating

© Fire Retardants Inc. All Rights Reserved.

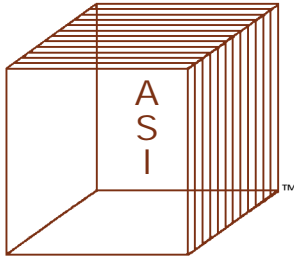

Architectural Surfaces, Inc.

DISTINCTIVE WOOD & SPECIALTY ACOUSTICAL CEILING & WALL SYSTEMS

123 Columbia Court North • Suite 201 • Chaska, MN 55318
952-448-5300 • Fax: 952-448-2613 • Toll Free: 1-800-710-8791
e-mail: info@architecturalsurfaces.net
Visit Our Web Site at www.architecturalsurfaces.net

CEILINGS YOU CAN LOOK UP TO!

BURN BARRIER™ 167 CLEAR OVERCOAT FOR CLEAR CLASS "A" FIRE RETARDANT VARNISH FOR BURN BARRIER 166

Product Description:

BURN BARRIER™ 167 Overcoat has been tested and rated by the Underwriter's Laboratories as an overcoat for BURN BARRIER™ 166 Class "A" Fire Retardant "Intumescent" Varnish. BURN BARRIER™ 167 is available in three distinctive sheens, i.e. low, semi or hi-gloss. The use of BURN BARRIER™ 167 as a topcoat over BURN BARRIER™ 166 greatly improves the moisture resistance, durability, and cleansibility of BURN BARRIER™ 166. We recommend that BURN BARRIER™ 167 be used over BURN BARRIER™ 166 on all surfaces that will be subjected to washing, handling or where a low, semi or hi-gloss finish is desired. *NOTE: FRI 167 is part of a fire retardant varnish system and is not a fire retardant when used alone.*

Surface Preparation:

After the application of BURN BARRIER™ 166 Class "A" Fire Retardant "Intumescent" Varnish has been completed, allow the surface to dry a minimum of 48 hours. Remove all dust, dirt, etc., from the surface, before applying BURN BARRIER™ 167 Overcoat.

Application:

BURN BARRIER™ 167 Overcoat can be applied by brush, roller or spray. Stir material well before using, then apply a uniform coat at a coverage rate up to 600 sq. ft./gal. In hard use areas or where excessive wear is expected, a second coat is suggested. Allow at least 24 hours drying time between coats.

Thinners:

For thinning use only BURN BARRIER™ 167 reducer. MINERAL SPIRITS or BURN BARRIER™ 167 Reducer may be used for cleaning.

WARNING

Adequate ventilation must be provided during and after application, until the coating has dried. Avoid breathing vapors or spray mist.

CAUTION

The liquid coating contains volatile (combustible) solvents. Due care must be exercised during and after application until coating is dry.

Fire Tests:

Flame Spread Rating: Class "A", when applied as a topcoat over BURN BARRIER™ 166 and tested in accordance with ASTM E84 (NFPA255) the coating system obtained the following fire hazard classification. A complete report from the Underwriters' Laboratories is available upon request.

© Fire Retardants Inc. All Rights Reserved.

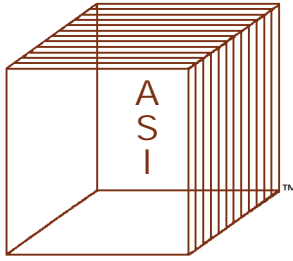

Architectural Surfaces, Inc.

DISTINCTIVE WOOD & SPECIALTY ACOUSTICAL CEILING & WALL SYSTEMS

123 Columbia Court North • Suite 201 • Chaska, MN 55318
 952-448-5300 • Fax: 952-448-2613 • Toll Free: 1-800-710-8791
 e-mail: info@architecturalsurfaces.net
 Visit Our Web Site at www.architecturalsurfaces.net

CEILING YOU CAN LOOK UP TO!

FIRE HAZARD CLASSIFICATION

Coating System Details

(When Applied to Douglas Fir)

	*Flame FSC	Spread (GWL)	Smoke Developed	Fuel Contributed
Type 6 (sealer) applied in one coat at 400 sq. ft./gallon				
Type 166 (base coat) applied in two coats at 300 sq. ft./gallon per coat				
Type 167 (top coat) applied in one coat at 1800 sq. ft./gallon	25	(15)	30-50	10

*Flame Spread Ratings FSC = Canadian Ratings
 (GWL) = U.S. Ratings

Packaging

Standard packaging, 1 gallon, 5 gallon and 55 gallon containers.

Information provided herein is based on tests believed to be reliable. Inasmuch as Fire Retardants Inc. has no control over the use or application to which others may put this material, we make no guarantee or warranty. Our products are sold on the condition that each user of the material make their own evaluation to determine the material's suitability for their own particular use.

NOTE: All porous surfaces should be properly sealed before applying fire retardant paint or varnish.

CAUTION: It is recommended that a test application be completed prior to end use.

© Fire Retardants Inc. All Rights Reserved.

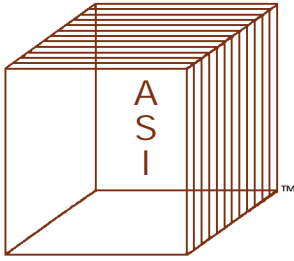

Architectural Surfaces, Inc.

DISTINCTIVE WOOD & SPECIALTY ACOUSTICAL CEILING & WALL SYSTEMS

123 Columbia Court North • Suite 201 • Chaska, MN 55318
952-448-5300 • Fax: 952-448-2613 • Toll Free: 1-800-710-8791
e-mail: info@architecturalsurfaces.net
Visit Our Web Site at www.architecturalsurfaces.net

CEILING YOU CAN LOOK UP TO!

Finishes

All of our wood systems are available factory pre-finished. Commercial projects typically require solid wood products to be finished with an intumescent Class A fire retardant varnish to meet local fire codes. Standard and catalyzed lacquer finishes are also available that are typically used on veneer faced products that have Class A Fire particle board core. We typically match customers stain samples for color approval.

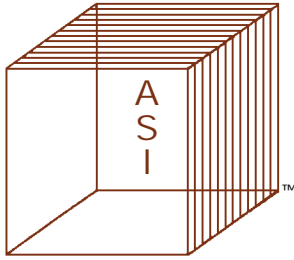

Architectural Surfaces, Inc.

DISTINCTIVE WOOD & SPECIALTY ACOUSTICAL CEILING & WALL SYSTEMS

123 Columbia Court North • Suite 201 • Chaska, MN 55318
952-448-5300 • Fax: 952-448-2613 • Toll Free: 1-800-710-8791
e-mail: info@architecturalsurfaces.net
Visit Our Web Site at www.architecturalsurfaces.net

CEILINGS YOU CAN LOOK UP TO!

Maintenance/Cleaning

Our wood products will require little maintenance. Surfaces may require standard dusting periodically. A feather duster can be used on the Woodcube™ and Woodgrille™ systems. A non-abrasive soft cloth with a light application of “Liquid Gold” applied to the cloth should be used to clean or dust flat panels or linear systems.

